

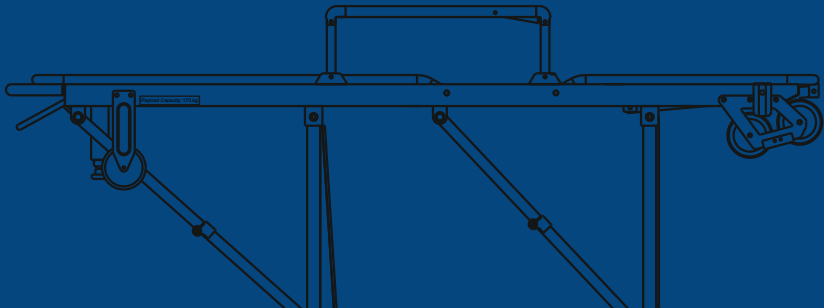

Ambulance Stretcher's

USER MANNUAL



SAFETY INFORMATION

Warning

Warning notices point out a potentially dangerous circumstance which, if not avoided, could result in injury or death. Below is a complete list of Warnings for Satpuda's Ambulance Stretcher.

Only trained operators must be allowed to operate the ambulance stretcher system as untrained operators can cause injury or get injured.

Incorrect use of stretcher's leg actuating levers, or using both levers at the same time, can cause the stretcher to descend and cause injury to the patient and/or operators. **Use stretcher's leg actuating levers only one at a time, and only as described in this manual.**

Use the stretcher only as described in this manual as incorrect use can cause injury.

Incorrect maintenance can cause injury. Maintain the ambulance stretcher system exactly as per the manual.

Lift the stretcher by holding the main frame only. Failure to lift from the main frame can cause injury or damage.

Improper parts and service can cause injury. Only Satpuda genuine spare parts must be used.

An unrestrained patient can get injured. Use restraints to secure the patient on the stretcher.

Modifying the ambulance stretcher system can cause injury and damage. Use the stretcher only as designed.

OPERATOR TRAINING

- Operators must read and understand this manual thoroughly
- Operators must be trained about the correct use of the ambulance stretcher system.
- Operators must have training on emergency-medical service and emergency patient-handling procedures.
- Operators must have the physical ability to assist the patient.
- Operators must practice with the stretcher before using it with a patient.

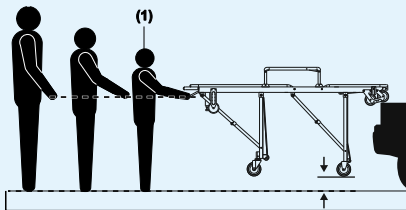

⚠ Warning

Untrained operators can cause injury or be injured. Permit only trained personnel to operate the ambulance stretcher system.

Stretcher unloading precaution

- During unloading, the control-end operator must lift and hold the weight of the stretcher, patient and equipment high enough for the wheels to remain off the ground until the legs unfold completely and lock. Supporting this weight requires greater strength from short operators than from tall operators because short operators must raise their arms higher in relation to their shoulders (1).
- If the ambulance is on an uneven surface, operators/helpers may need to lift the stretcher higher than normal to allow the legs to unfold and lock.

USING THE STRETCHER

Leg actuating lever

- The leg-actuating levers (1) unlock the legs and allow them to fold. The green handle collapses the front legs. The red handle collapses the rear legs.
- The leg actuating levers are not used to unfold the stretcher or unload it from an ambulance. Control handles are used only to collapse the legs.
- To load the stretcher into an ambulance, the control-end operator operates one actuating lever at a time

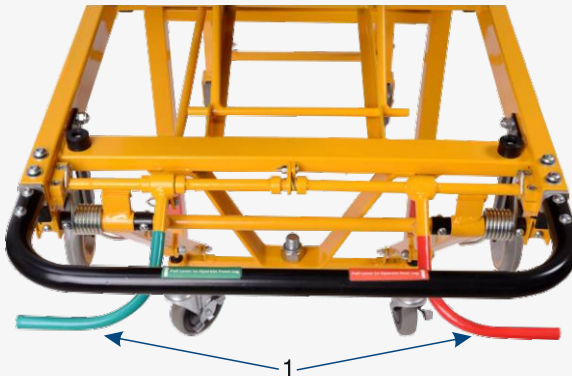

Warning

Improper use of stretcher leg actuating levers, or using both levers at the same time, can cause the stretcher to descend and injure the patient and / or operators. Use stretcher actuating lever only one at a time, and only as described in this manual. Ensure that both the green and red actuating levers are not kept pressed while unloading the stretcher from ambulance.

USING THE STRETCHER

Side Railings

- Side railings provide safety and comfort to the patient. Keep side railings raised except when transferring a patient onto or off the stretcher.
- **To lower** : Push the red locking lever (2) inside and push the side railing (3) sideways in the indicated direction.
- **To raise** : Lift the side railing up until it locks.



Notice

Do not use side railings to lift the stretcher. Side railings are not designed for lifting. Lift the stretcher only by grasping the stretcher main frame.

USING THE STRETCHER

Leg rest

- The Leg rest (4) allows the operator to lift the patient's legs to treat shock or for patient comfort.
- **To raise :** Stand at the control-end of the stretcher. Use both hands to lift the leg rest until the ratchet rod (5) falls inside the ratchet slot (6) and then release the leg rest to lock on its own.
- **To lower :** Stand at the control-end of the stretcher. With one hand lift the leg rest until the ratchet rod is out of the ratchet slot, then with the other hand lift the ratchet rod upwards and gradually lower the leg rest with the other hand until the leg rest touches the main frame of the stretcher.



Warning

An uncontrolled leg rest can injure the operator and/or patient. Assume the weight of the leg rest and patient before using the leg rest.

Operating the leg rest inside the ambulance can lead to operator or patient injury. If possible, adjust the leg rest before loading the stretcher into the ambulance.

USING THE STRETCHER

Backrest

The backrest (7) adjusts between five positions. The lowest position is always unlocked. Positions 2 – 5 lock and unlock using the backrest control lever (8).

Raising the Backrest

- Assume the weight of the backrest and patient.
- To raise from the lowest (unlocked) position 1: From the loading-end of the stretcher, raise the backrest to the second position. The backrest will automatically lock without operating the control lever.
- To raise from positions 2 – 4 : From the loading-end of the stretcher, squeeze the backrest control lever (8) to unlock, then raise the backrest to the desired position. Release the backrest control lever to lock it into the new position.



Lowering The Backrest

- Assume the weight of the backrest and patient.
- **To lower from positions 3 – 5 :** From the loading-end of the stretcher. Squeeze the backrest control lever (8) to unlock, then lower the backrest to the desired position. Release the backrest control lever to lock it into positions 2 – 4.
- **To lower from position 2 :** Reach under the main frame (9) and squeeze the backrest control lever (8) to unlock. Carefully lower the backrest to the lowest (unlocked) position.

Warning

Operating the backrest inside the ambulance can lead to operator or patient injury. If possible, adjust the backrest before loading the stretcher into the ambulance.

An uncontrolled backrest can injure the operator and/ or patient. Assume the weight of the backrest and patient before adjusting the backrest height.

USING THE STRETCHER

- Wheel locks help keep the stretcher stationary during patient transfer and certain medical procedures. When engaged, the wheel lock stops wheel rotation.
- Press the ON part of the lever (9) down to engage.
- Press the OFF part of the lever (9) down to disengage.

Wheel locks

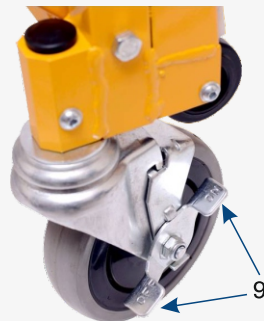

USING THE STRETCHER

Locking base

- Pull the locking lever (10) with one hand and hold it.
- Use your other hand to pull the stretcher slightly outwards until the stretcher's wheel rod is out of the front locking flaps.
- Once the stretcher's wheel rod is out of the front locking flaps, release the locking lever and pull the stretcher out of the vehicle.

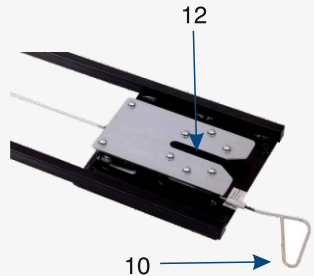

Guide pin alignment

- Ensure that the stretcher's guide pin head (11) does not rub against the locking base guide slot (12) while loading or unloading the stretcher from the ambulance.
- If you notice that the guide pin head is rubbing against the locking base guide slot then use a 24 mm spanner along with an Allen key of size 10 and loosen the guide pin head to create a small gap between guide pin head and locking base guide slot.

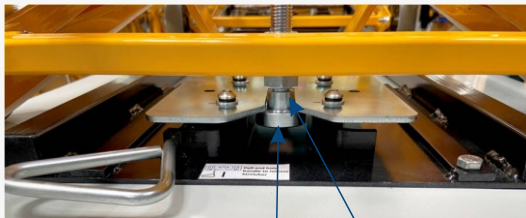

11

12

MAINTENANCE

Maintenance schedule

The ambulance stretcher system requires regular maintenance. Set up and follow a maintenance schedule. The table below represents minimum intervals for maintenance. Keep maintenance records.

When using maintenance products, follow the manufacturers' directions and read the manufacturers' material safety data sheets.

Minimum Maintenance	Each use	As needed	Monthly
Disinfect	✓		
Clean		✓	
Inspect		✓	✓
Lubricate		✓	

Disinfectants and cleaners containing bleach, sodium hypochlorite, phenolics or iodines can cause damage. Do not use products containing these chemicals. Use only Benzalkonium Chloride or Cresol Emulsion to clean / disinfect the stretcher.

Warning

Water under high pressure, or steam, can penetrate joints, flush away lubricant, and cause corrosion. **Use caution when cleaning moving parts such as joints and hinges, and reapply lubricant if needed.**

Using abrasive cleaning compounds or applicators on the stretcher can cause damage. Do not use abrasive materials to clean the stretcher.

MAINTENANCE

Inspecting the stretcher

Follow the inspection checklist and operate the stretcher through all its functions as described in this manual. If inspection shows damage or excessive wear, remove the stretcher from service until repair is made.

Inspection check list

- Are all components present?
- Is the stretcher free of excessive wear?
- Are all screws, nuts, bolts securely in place?
- Do all moving parts operate smoothly and properly?
- Do the legs lock, unlock, and fold properly?
- Does the stretcher load and unload properly?
- Does the stretcher roll smoothly?
- Do the wheels have excessive wear?
- Are the patient restraints properly installed?
- Is the patient mattress in good condition without rips, tears, or damage?
- Is patient-restraint webbing in good condition with no cuts or frayed edges?
- Are patient-restraint buckles free of visible damage and do they operate properly?
- Is the ambulance properly prepared for the stretcher with an approved locking system installed?
- Do installed accessories operate properly without interfering with stretcher operation?

Lubricating the stretcher

Disinfect and clean the stretcher and rail before applying lubricant. Use the lubricants designated below to lubricate the stretcher and rail. Use a small amount of lubricant. Lubricate identical points on each side of the stretcher and rail. After applying, wipe off excess.

Lubrication points

Stretcher leg hinges and pivot points -
Use light weight synthetic oil.

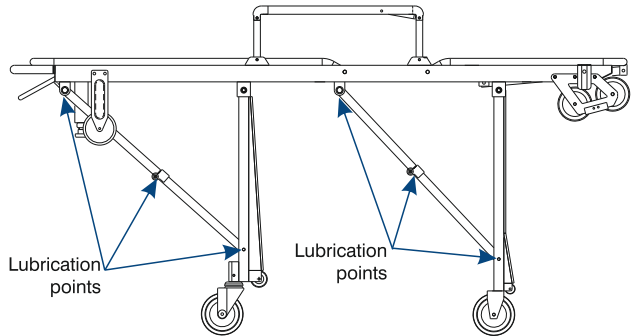

F-13, MIDC, Ambad,
Nashik 422010, (MH), India ,

91 253 6601204/5
9920862845, 7709046789

sales@satpudaindia.com,
www.satpudaindia.com

MADE IN
INDIA